



IP2358EN • 2020-02-14

Dítec



Dítec EL500E

Made in Italy 

Installation manual for digital control unit for 3-phase motors with encoder or mechanical limit switches

(Translation from original instructions)

Index

DESCRIPTION	4
DIRECTIVES	4
TECHNICAL DETAILS	5
1. ENCLOSURE INSTALLATION	8
2. ELECTRICAL OPERATING INSTRUCTIONS	8
2.1 CONTROL UNIT POWER SUPPLY	8
2.2 MOTOR POWER SUPPLY	9
3. PUSH BUTTONS	9
3.1 ADDITIONAL CONTROL BUTTONS	9
4. CONTROL UNIT SET-UP	10
4.1 SET-UP MODE ACTIVATION	10
4.2 BASIC PROGRAMMING	10
4.3 RESET PROCEDURE	11
5 OPERATION WITH ENCODER MOTOR	12
5.1 CONNECTING ENCODER LIMIT SWITCHES	12
5.2 CONFIGURATION OF ENCODER LIMIT SWITCH	13
5.3 ENCODER LIMIT SWITCH ADJUSTMENT	14
5.4 FINE-TUNING OF ENCODER LIMIT SWITCH	15
6. OPERATION WITH MOTOR WITH MECHANICAL LIMIT SWITCHES	16
6.1 CONNECTING MECHANICAL LIMIT SWITCHES	16
6.2 CONFIGURATION FOR MECHANICAL LIMIT SWITCH	17
7. OPERATION MODE	17
8. WORKING TIME SET-UP	18
9. AUTOMATIC CLOSING	18
10. "CAR WASH" FUNCTION	19
11. TEMPORARY DISABLING OF AUTOMATIC CLOSING	19
12. PARTIAL OPENING WITH ENCODER LIMIT SWITCHES	20
12.1 AUTOMATIC CLOSING FROM PARTIAL OPENING	20
13. SAFETY DEVICES	21
13.1 PHOTOCELLS	21
13.2 SAFETY EDGE	22
13.3 SECONDARY MOVABLE SAFETY EDGE	23
13.4 AUX RELÈ MANGEMENT (max 230Vac/5A)	23
14. PARAMETER LIST	24
15. FLASHING LIGHT CONNECTION (230Vac with self-flashing) / COURTESY LIGHT	27
15.1 FLASHING LIGHT	27
15.2 COURTESY LIGHT	27
15.3 ADDITIONAL RADIO RECEIVER MODULE NRGZENX1 (OPTIONAL)	28
15.4 "GO FUNCTION"	28
16 SIGNAL VISUALIZED ON THE DISPLAY	29
17. TROUBLESHOOTING	30
17.1 ERROR CODES - D15 ERROR LED	30
17.2 DISPLAY ERROR CODE	31

GENERAL SAFETY PRECAUTIONS



Failure to observe the information given in this manual may lead to personal injury or damage to the equipment. Keep these instructions for future reference

This installation manual is intended for qualified personnel only.

Installation, electrical connections and adjustments must be performed in accordance with Good Working Methods and in compliance with the present standards.

This product must only be used for the specific purpose for which it was designed.

Any other use is to be considered improper and therefore dangerous. The manufacturer cannot be held responsible for any damage caused by improper, incorrect or unreasonable use.

Read the instructions carefully before installing the product. Incorrect installation may cause danger.



The packaging materials (plastic, polystyrene, etc.) should not be discarded in the environment or left within reach of children, as they are a potential source of danger.

Before installing the product, make sure it is in perfect condition.

Do not install the product in explosive areas and atmospheres: the presence of inflammable gas or fumes represents a serious safety hazard.

The safety devices (photocells, safety edges, emergency stops, etc.) must be installed taking into account the applicable laws and directives, Good Working Methods, installation premises, system operating logic and the forces developed by the automation. Before connecting the power supply, make sure the plate data correspond to those of the mains power supply. An omnipolar disconnection switch with a contact opening distance of at least 3mm must be fitted on the mains supply.

Check that there is an adequate residual current circuit breaker and a suitable over-current cutout upstream of the electrical installation in accordance with Good Working Methods and with the laws in force.

When requested, connect the automation to an effective earthing system that complies with current safety standards.



During installation, maintenance and repair operations, cut off the power supply before opening the cover to access the electrical parts.



The electronic parts must be handled using earthed antistatic conductive arms. The manufacturer of the motorisation device declines all responsibility if component parts not compatible with safe and correct operation are fitted.

Only use original spare parts when repairing or replacing products.

DESCRIPTION

Specific use

The control unit is specific for doors moved by a single motor.

Safely operation are guaranteed only with the normal specific use.

Ditec is not responsible for improper use or non-compliance with safety instruction contained in this manual.

No-changes are permitted, otherwise the declaration of conformity will be considered void.



WARNING: it is recommended to activate the impulsive mode only after having completed the set-up and adjustments of the control unit. In particular, during the limit switches adjustment select only the deadman operation mode.

Spare parts

Use only original spare parts.

DIRECTIVES

Entrematic Group AB declares that the Ditec EL500E control panel complies with the fundamental requisites and other relevant requirements laid down by the following EC directives:

Directives – EMC Directive 2014/30/EU

EN 61000-6-3 (2007) + A1:2011 Emission – Residential

EN 61000-6-1 (2007) Immunity – Residential

EN 61000-6-4 (2007) Emission – Industry

EN 61000-6-2 (2005) Immunity – Industry

EN 61000-4-3 (2006) +A1(2008) +A2(2010) RF-field immunity

EN 60335-1 (2012)/AC:2014 Safety – Part 1: General requirements

Directives – Low Voltage Directive LVD 2014/35/EU

EN 60335-1 (2012)/AC:2014 Safety of Household and similar electrical appliance/ Part 1.

EN335-2-103:2015

Technical documentation of safe integration provided.

TÜV certificate conformity with:

EN 12453 (2017) Industrial, Commercial and garage doors and gates. Safety in use

EN ISO 13849-1:2015 Safety of machinery

The production process is aimed to ensure the compliance of the equipment with the technical documentation and it is regularly evaluated by an independent certifying body.

Technical dossier manager:

Matteo Fino E-mail: matteo.fino@entrematic.com

Entrematic Group AB

Lodjursgatan 10

SE -261 44 Landskrona

Sweden

Location Date

Landskrona 14-02-2020

Signature

Matteo Fino

TECHNICAL DETAILS

Installation	Vertical on a flat wall
Temperature range (operating)	-10°C / +50°C
Humidity	Up to 93% RH non-condensing
Degree of protection	IP54
PCB dimension	163x225x80mm
Supply voltage	3x400VAC; 50/60Hz; ± 10% L1,L2,L3,N,PE 3x230VAC; 50/60Hz; ± 10% L1,L2,L3,PE Mains fuse max: 3 x 10A Rated insulation voltage $U_i = 400V$
Transformer	Max 13 VA, VDE 0570/EN61558 Primary 230VAC winding is thermal protected by built-in thermal transformer fuse. Both secondary windings are overload protected by multifuses.
Motor output	Max motor load by 3x400VAC: 4kW Max motor load by 3x230VAC: 2.3kW Max motor current: 8.5A
Emergency stop, Stop, Thermo spec. door stop and Safety chain	Function as normal stop command and disconnect power to contactor coils
24VDC Output (terminals X3-18,X3-19)	24VDC ± 20% (non-regulated), Max load: 250mA
Safety edge input	PNE/air switch Electric type - 8.2K Ω termination ± 10% Optical type Performance level C, Category 2
Optical safety edge	Input voltage level high (green): 2.5 - 5.0V Input voltage level low (green): < 0.5V Input frequency range (green): 250 - 2000Hz (50% duty-cycle) Pulse interval maximum (green): 7.0ms (when not 50% dutycycle)
Photocell input	X3-18, 22 or X12 1, 3 External photocell, 24VDC (e.g. self contain photocell) Performance level C, Category 2
Electronic limits	RS485, Data+ Data-, terminated with 120 Ω
Relé (K3+ X17)	Contatti Max 230VAC / 5A
Box dimension	210x305x120mm

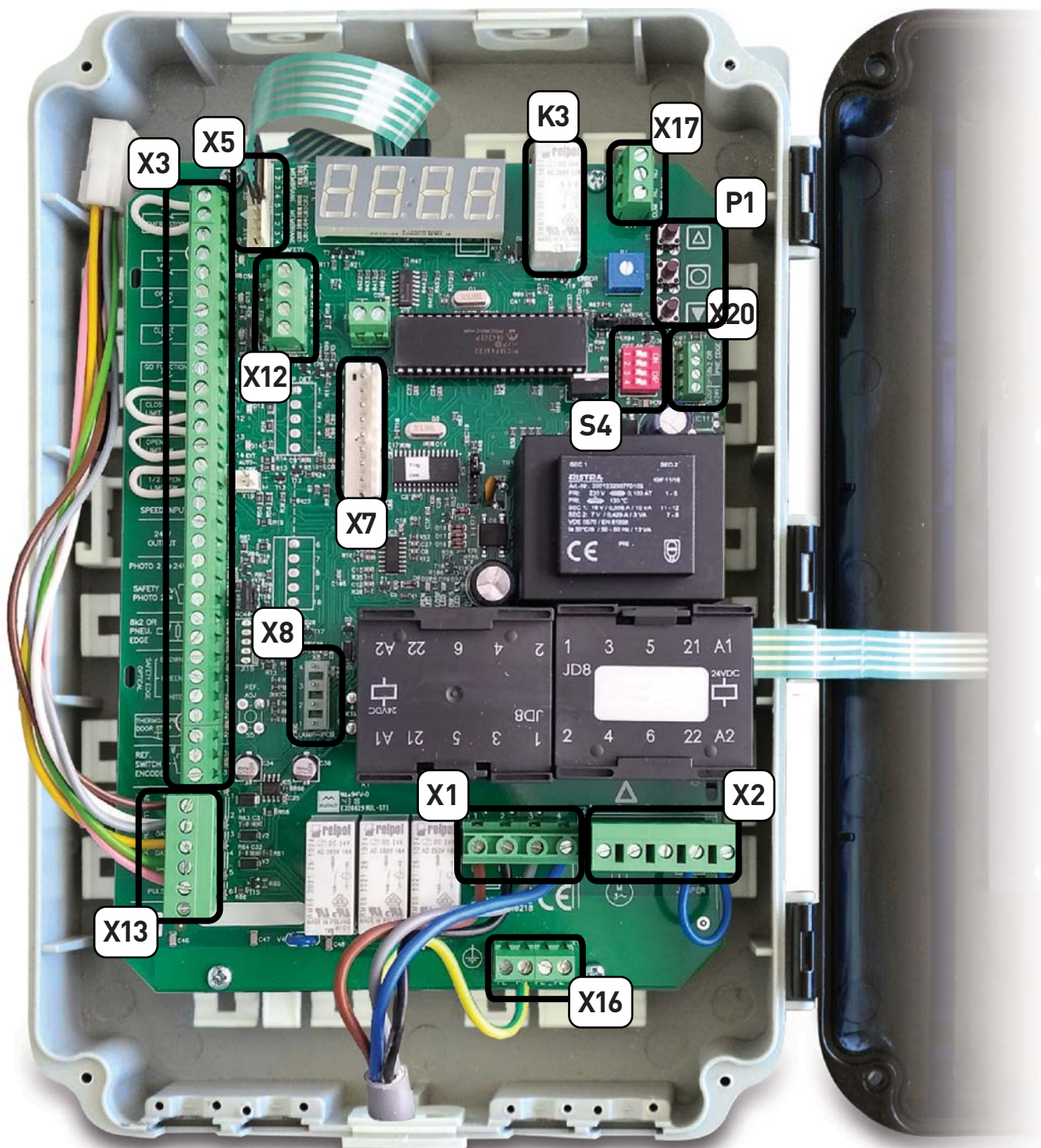

X1 MAIN SUPPLY TERMINAL (L1, L2, L3, N)	P1 PUSH-BUTTON
X2 PLUG IN CONNECTOR FOR MOTOR (U, V, W)	X7 SLOT MODULO RADIO NRGZEN1
X3 TERMINALS FOR SAFETY DEVICES	X8 TRAFFIC LIGHT LAMP SLOT NRGFTL - OPTIONAL
X5 INTEGRATED PUSHBUTTON	X13 TERMINALS FOR ABSOLUTE ENCODER
X12 PHOTOCCELL 1 TERMINALS (PHOTO 1)	X16 GROUND TERMINALS ⊕
X17 TERMINALS FOR AUXILIARY DEVICES - AUX RELAIS MANAGEMENT	S4 DIP SWITCH FOR PROGRAMMING
	X20 SECONDARY MOVABLE SAFETY EDGE

FIG. 1

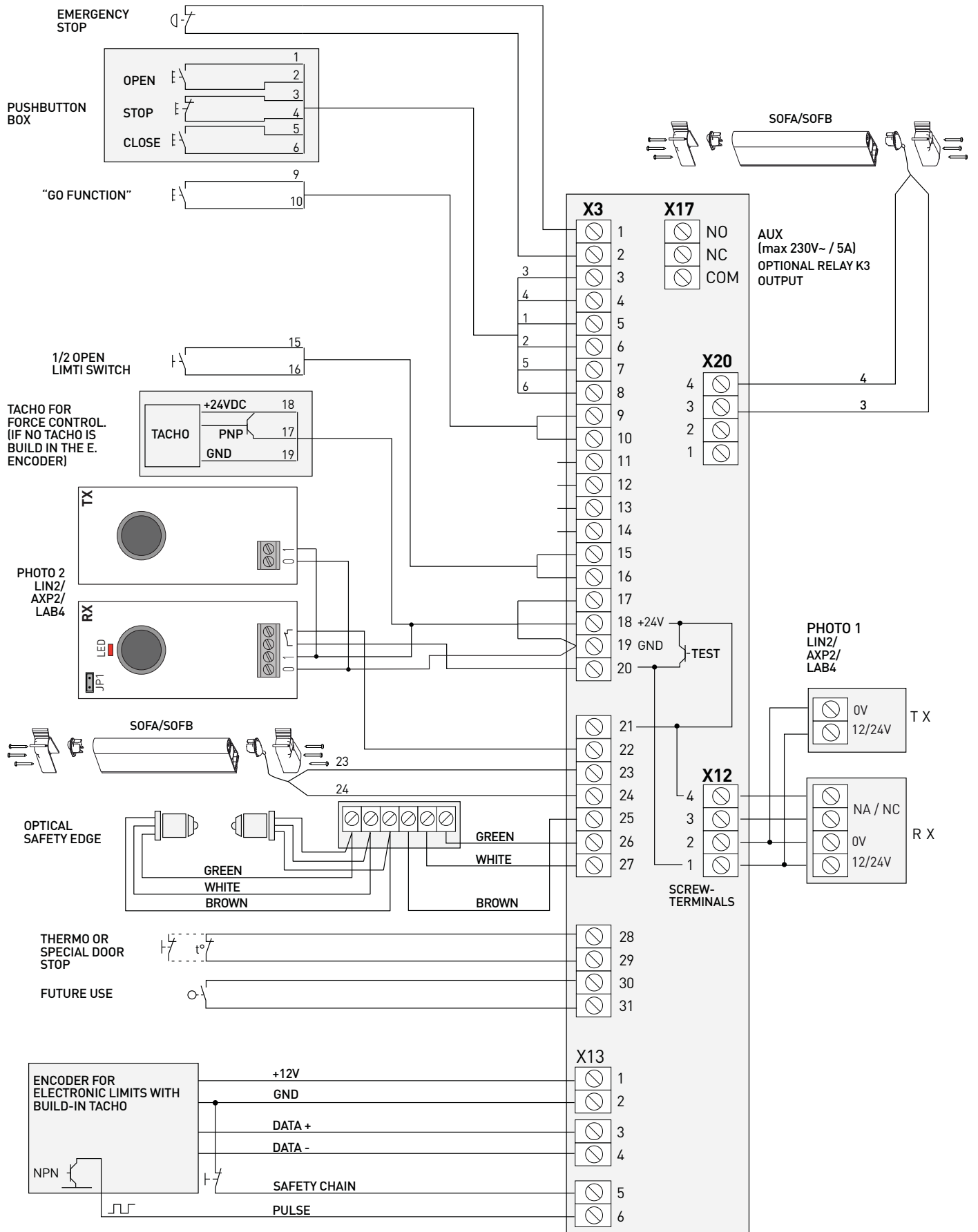

1. ENCLOSURE INSTALLATION

For a correct installation:

- Install where the control unit can be protected from rain or adverse weather conditions.
- Mounting must be vertical.
- The surface has to be checked for flatness, slope and freedom from vibrations.
- Do not install in an area of potential risk of condensation.
- It is important that the door can be clearly seen from the position of the control through its travel.
- Install in an area not accessible to children or unauthorized persons.
- Do not perform any electrical connections before the enclosure installation is completely accomplished.

2. ELECTRICAL OPERATING INSTRUCTIONS

(Read carefully and respect the connection's sequence).

! **IMPORTANT!** All the connection operations must be performed only after the main power supply has been disconnected.

TURN OFF THE MAIN POWER SWITCH BEFORE ANY OTHER OPERATION!

When connecting control to mains supply a mains isolator switch (16A CEE - plug) according EN 12453 is required. The supply disconnect device (main switch or CEE plug) must be installed between 0.6m and 1.7m above floor level.

2.1 CONTROL UNIT POWER SUPPLY

! **WARNING!** The installation must include an automatic cut off switch with minimum distance between the contacts of at least 3mm.

The control unit can be powered in two different modes: 400V~ 3-phase and 230V~ 3-phase. The power supply of the motor and of the control unit must correspond.

! **WARNING:** if you connect the wires differently from what is shown in the diagrams you can damage the motor and the control unit and endanger the safety of the installer.

Here below shown the connection diagrams based on the selected power supply:

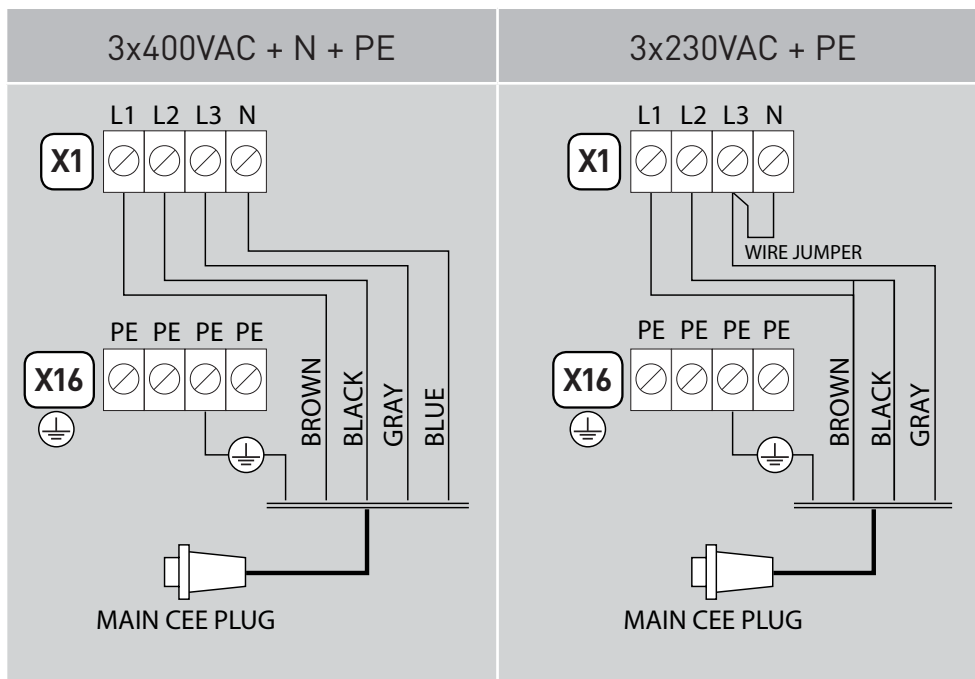

If you need to disconnect the power cable and then to reconnect it or change the control unit wiring sequence, you HAVE To connect the wires properly (following the diagram above), restoring the original configuration. Take care to connect the ground wire to the X16 terminal.

2.2 MOTOR POWER SUPPLY



IMPORTANT! All the connection operations must be performed only after the main power supply has been disconnected.

TURN OFF THE MAIN POWER SWITCH BEFORE ANY OTHER OPERATION!

After installation it is possible to connect motor and central unit with cable Ditec NRG CAB:

- Connect free wires to the X2 terminal (as shown here on the side), and verify the direction of the motor rotation.
- Link the ground conductor to connector X16.



WARNING! Verify the direction of rotation of the motor supplied with 400V or 230V 3-phase: by pressing the OPEN button (S2) the door has to open while, by pressing the CLOSE button (S3), the door must close.

In case of wrong direction, reverse two of the phases (L1, L2 and L3) on the X1 terminal.

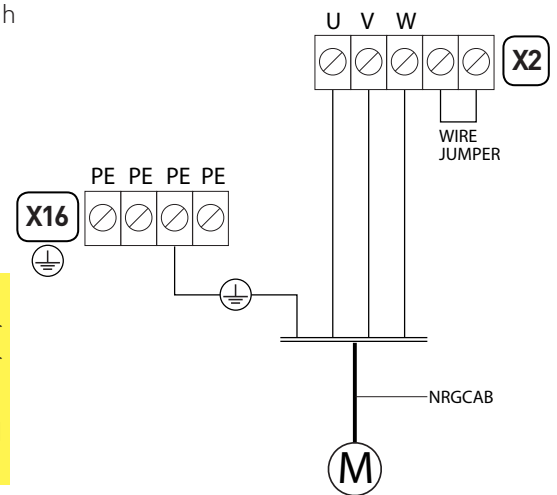

3. PUSH BUTTONS

The keyboard on the cover of the control unit is connected to terminal X5 through the flat cable (A): if you need to disconnect the flat and then to reconnect it, pay attention to the direction of connection (reference point B).

3.1 ADDITIONAL CONTROL BUTTONS

You can connect additional control pushbuttons through the terminals from 3 to 8 of the X3.

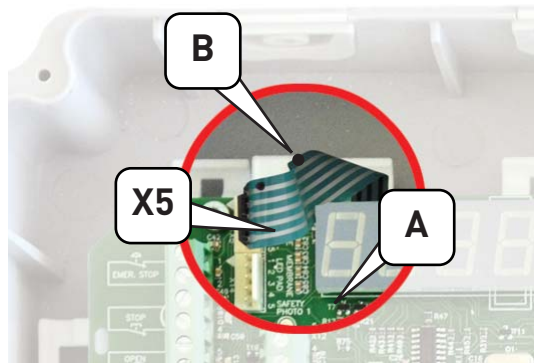

To do it:

1. connect a normally closed button, eliminating the standard jumper, to the contacts 3 and 4 for the STOP command;
2. connect a normally open button to the contacts [5] and [6] for the OPEN command (S2);
3. connect a normally open button to the contacts [7] and [8] for the CLOSE command (S3).



PAY ATTENTION AT THE CONNECTIONS! No line voltage (230V~ or other external devices) can be connected to the buttons otherwise the unit is damaged.

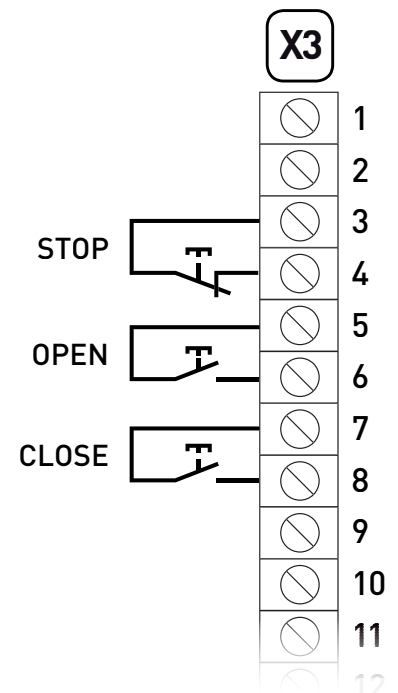

4. CONTROL UNIT SET-UP

! The set-up must be performed with the motor off. Follow carefully the steps as described in the procedures, DO NOT activate any safety, hand controls or radio controls unless specifically requested by the procedure.

Basically the set-up of the control and the right coupling control/motor must be performed by the installer.

4.1 SET-UP MODE ACTIVATION

To enter the control unit programming mode place the DIP1 of the switch (S4) in ON.

During set-up the control unit will work only in dead man mode.

To return to the normal operating mode, place the DIP1 of the switch (S4) in OFF.

4.2 BASIC PROGRAMMING

The control unit is supplied with a basic setting performed at the factory which can be restored at any time with the reset procedure (see paragraph 4.3).

Before beginning the programming procedure:

1. Open the cover of the unit.
2. Make sure all the connections have been made correctly and that the emergency stop or other safety devices are not activated. Otherwise the display shows the stop symbol active .
3. Find the buttons OPEN (S2) - CLOSE (S3) - STOP (S1) and the 4 switches (S4) on the board.
4. Ensure that the LED D10 is not flashing (in case it flashes, check again point 2).

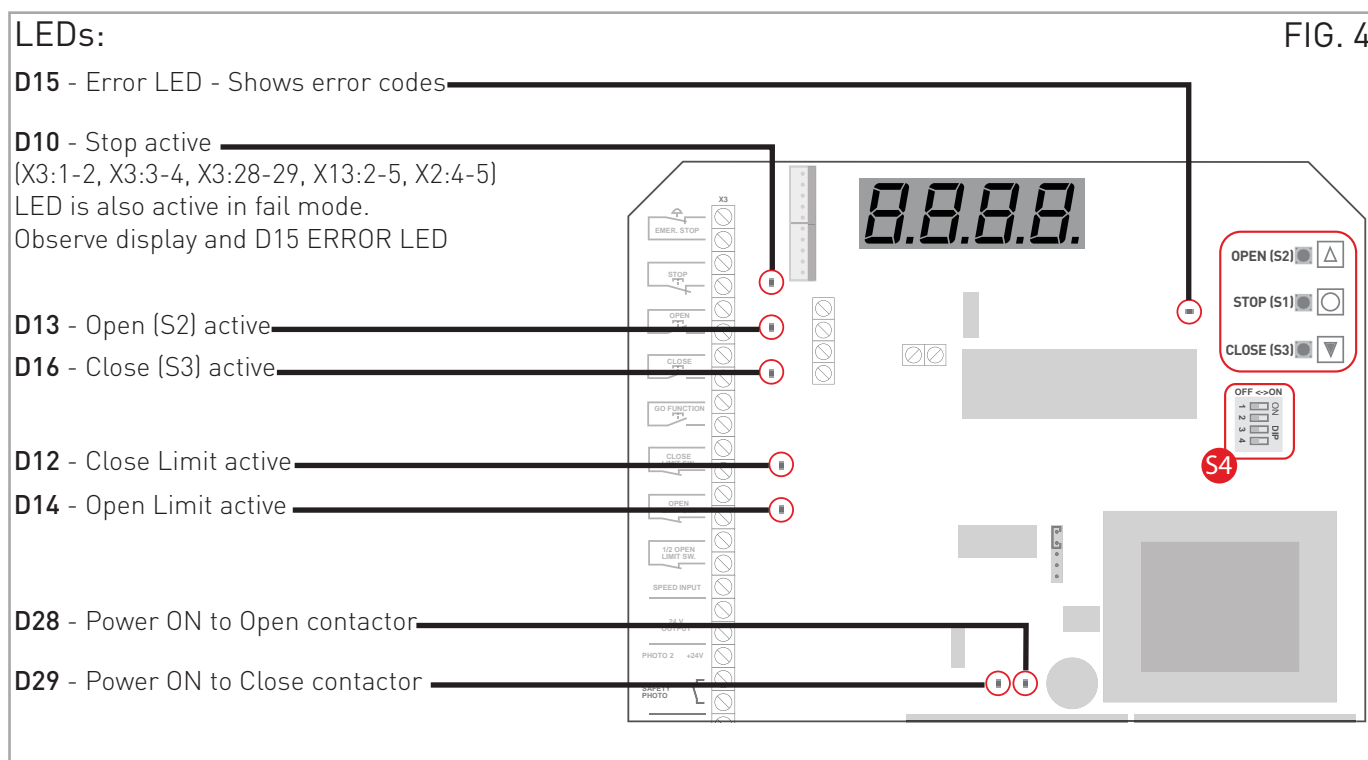



NOTE: when the control unit is power on, the display shows 4 digits about the firmware version.

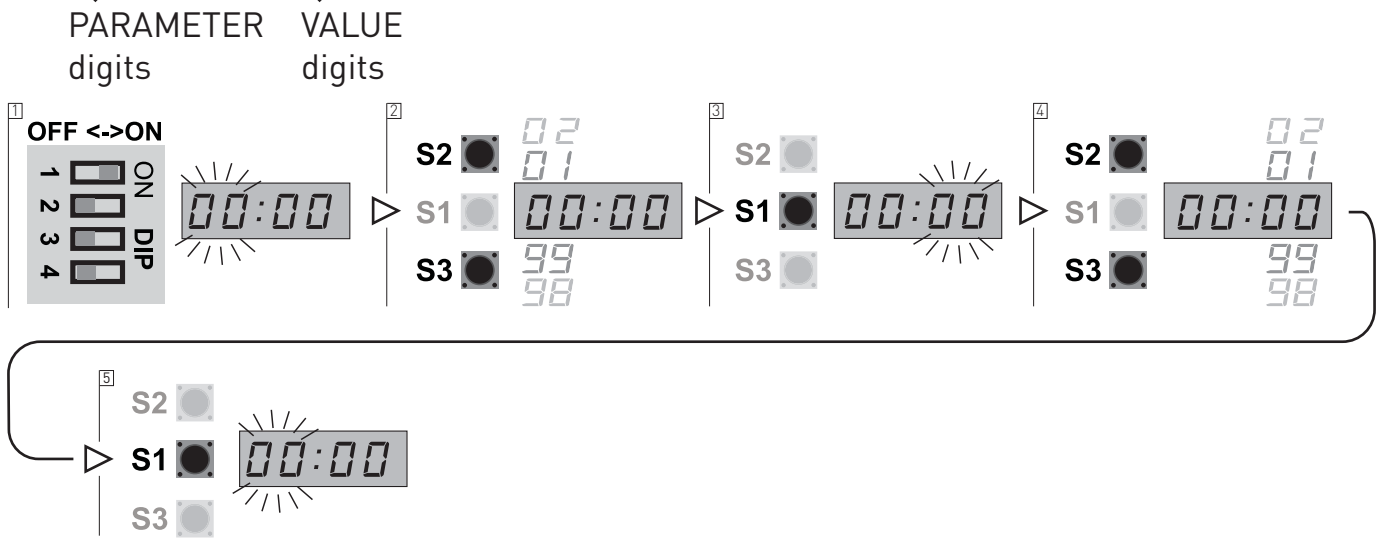

STOP (S1) button: to switch from PARAMETER field to VALUE field.

OPEN (S2) / CLOSE (S3) buttons: to increase or decrease the size of the fields PARAMETER and VALUE

1. Put DIP switch 1 (S4) in ON position, PARAMETER digits start blinking
2. Select by OPEN (S2) / CLOSE (S3) buttons the number desired
3. Confirm by STOP (S1) button the PARAMETER selected. The VALUE digits start blinking
4. Select by OPEN (S2) / CLOSE (S3) buttons the number desired
5. To confirm the VALUE selected and return to PARAMETER field press STOP (S1) button



NOTE: Some parameters require a further selection after pressing the STOP button (S1) as confirmation of the desired value. For example, to operate the door during the limit switch set-up the display shows **RUN**. The complete list of the parameters and values is available to the paragraph 13.

4.3 RESET PROCEDURE

The reset procedure allows to erase the settled data of the control unit memory and to return to the default programming.

1. Put DIP 4 (S4) to ON position
2. Within 2 seconds press simultaneously the STOP (S1) / OPEN (S2) buttons
3. Display will shows **FAC** blinking and the control unit software version number
4. Put DIP 4 (S4) to OFF positio:

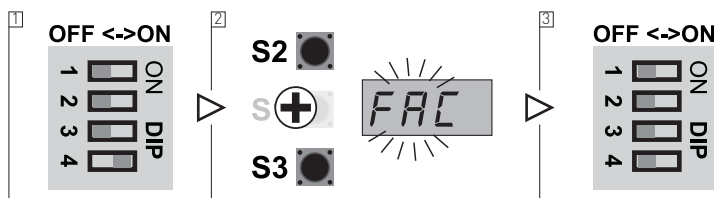

5 OPERATION WITH ENCODER MOTOR

5.1 CONNECTING ENCODER LIMIT SWITCHES

The control unit is pre-set to the type of encoder limit switch.

The encoder limits switch wires are connected according to the diagram of fig. 5.

ATTENTION: if you connect a control unit pre-set for encoder limit switches to a motor with mechanical limits, the motor does not perform correctly. In particular, the motor will not find the limit positions and this could put at risk the safety of people and/or things.

The limit switches connector (1) of the multicore cable (NRGCAB) must be connected to the male connector (2) of the cable the control unit is provided with (Fig. 5a).

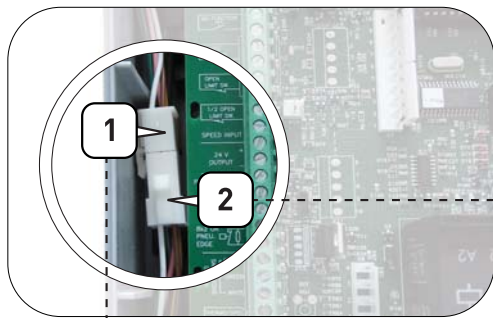
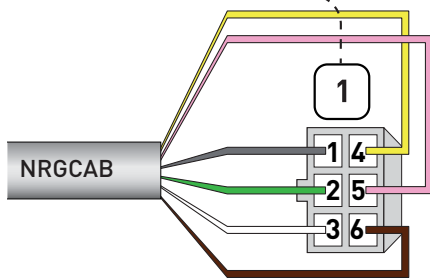

FIG. 5a



1	GREY	> GRD
2	GREEN	> DATA -
3	WHITE	> GRD
4	YELLOW	> DATA +
5	PINK	> SAFETY
6	BROWN	> +12V

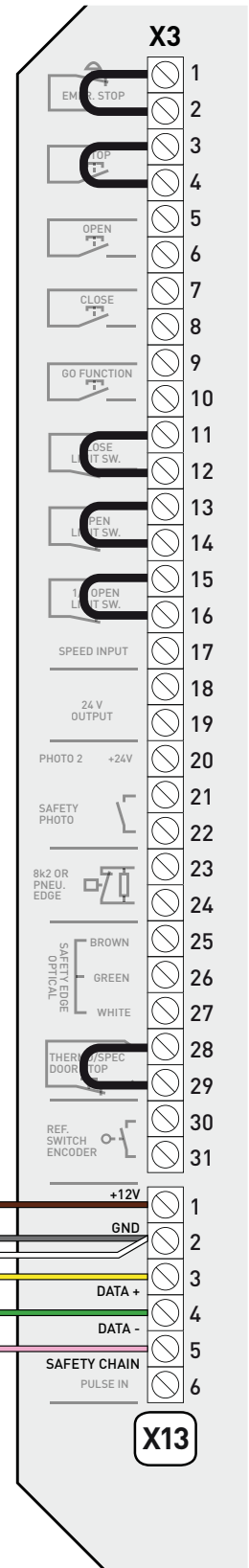
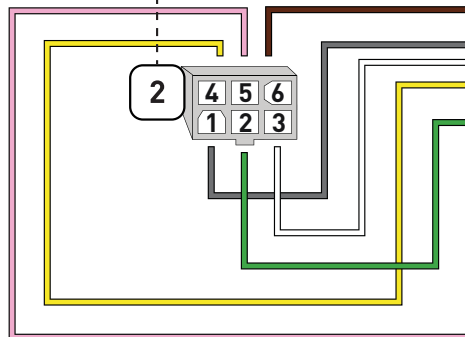

FIG. 5



NOTE: in case you are not using a Ditec NRG CAB cable, you have to use a cable with AMP 0172168 connector at both ends

5.2 CONFIGURATION OF ENCODER LIMIT SWITCH



WARNING: Connecting the motor and pressing the up button (↑) the door must go up, otherwise reverse the phases (see par. 2.2)

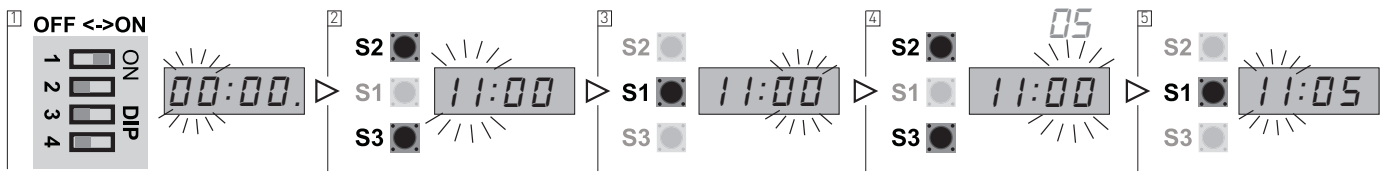

1. Put DIP 1 (S4) in ON position, PARAMETER digits start blinking
2. Select by OPEN (S2) / CLOSE (S3) buttons the number 11
3. Confirm by STOP (S1) button the PARAMETER selected. The VALUE digits start blinking
4. Select by OPEN (S2) / CLOSE (S3) buttons the VALUE:
 - **VALUE 05:** standard installation. Check the rotation direction of the shaft while the door going up (opening) as shown in fig. 5b;

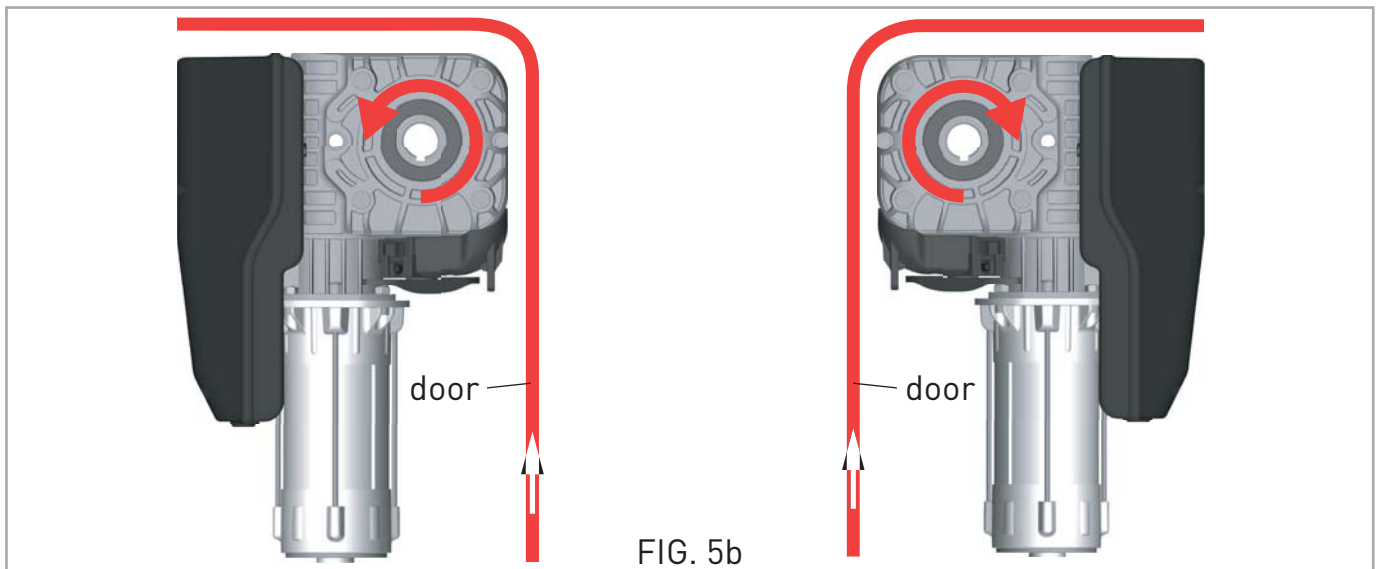

- **VALUE 06:** not standard installation. While the door going up (opening), the rotation direction is opposite compared to the previous case.
5. To confirm the VALUE selected and return to PARAMETER digits press STOP (S1) button
 6. To leave the set-up mode, place the DIP1 in OFF..

After selecting the type of digital limit switch with encoder it is necessary to cut off the power supply (by disconnecting the plug or by turning OFF the main switch) and then to connect it once again in order to allow the communication between the encoder and the control unit.



WARNING: Please follow the installation requirements of the Ditec motors.

For example, if a motor with encoder is installed in a way which the encoder direction is reversed, it will not run correctly and may put at risk things and/or people.

Ditec disclaims any responsibility from the consequences of an installation not accomplished according to this policy. After the selection of the encoder limit switch, it is necessary to proceed with the limit switches adjustment.

5.3 ENCODER LIMIT SWITCH ADJUSTMENT

! WARNING: Check that motor and control unit are connected.

By following the instructions in section 5.2, select the parameter **11** to the value **05** (or **06**). In this case the D15 LED will flash 2 times until both limit switches are not set.

In case the LED D15 blinks only one time, it is necessary to check the correct connection between encoder and control unit and that the correct limit switch type selecting procedure has been accomplished as shown in paragraph 5.2 including the shutdown of the unit after the selecting step in the case of standard Ditec encoder

NOTE:

- the PARTIAL OPENING function cannot be activated during programming (parameter 16) - Paragraph 12;
- the additional photocell on the door frame cannot be active during programming (parameter 31);
- When you change the limit switch positions the force control value (parameter 41) and operating time (parameter 51) will be reset to the factory default settings.

UP LIMIT SWITCH ADJUSTMENT

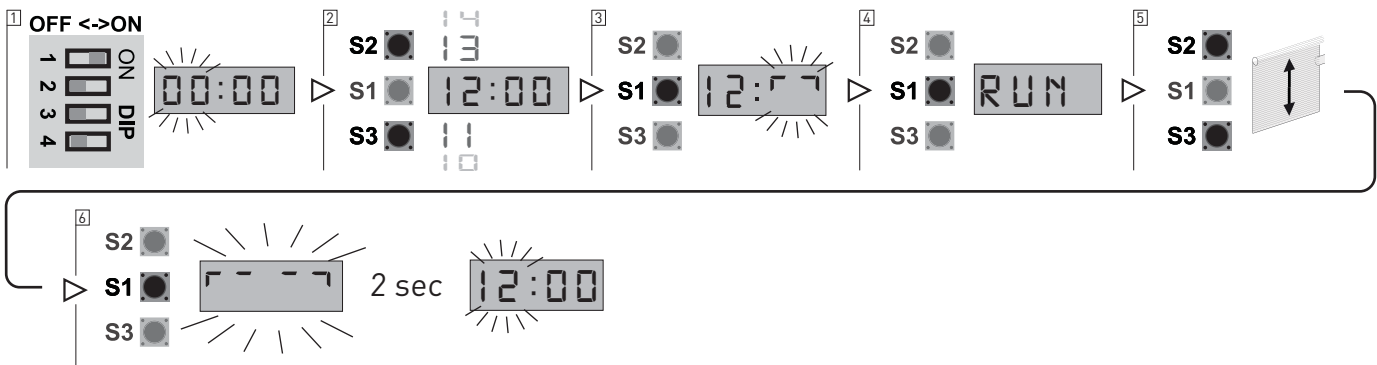

1. Put DIP 1 (S4) in ON position, PARAMETER digits start blinking
2. Using the buttons OPEN (S2) and CLOSE (S3) select the parameter 12
3. Access the field VALUE pressing STOP (S1). The field VALUE shows the flashing symbol
4. Press button STOP (S1) once again and the unit, showing the message **RUN**, is ready to move the door
5. Use buttons OPEN (S2) and CLOSE (S3) to reach the exact UP limit position
6. Press the STOP button (S1) to confirm the position. The display will show the symbol for 2 seconds and then the PARAMETER field will start flashing again (showing the number 12).
7. To leave the set-up mode, place the DIP1 in OFF.

DOWN LIMIT SWITCH ADJUSTMENT

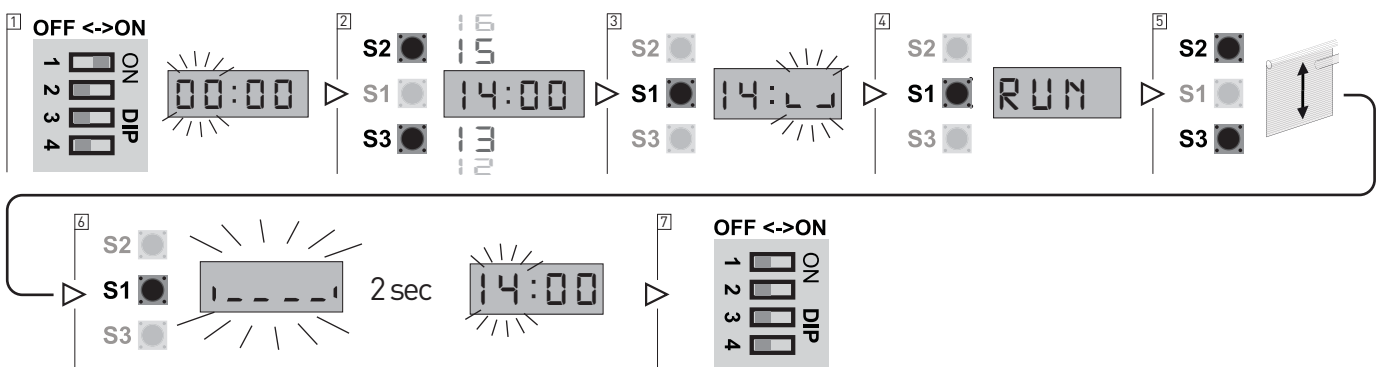

1. With the DIP1 of the S4 switch in ON and the PARAMETER field still blinking
2. Select by OPEN (S2) / CLOSE (S3) buttons the parameter 14
3. Access the field VALUE pressing STOP (S1). The field VALUE shows the flashing symbol
4. Press button STOP (S1) once again and the unit, showing the message **RUN**, is ready to move the door
5. Use buttons OPEN (S2) and CLOSE (S3) to reach the exact DOWN limit position.
6. Press the STOP button (S1) to confirm the position. The display will show the symbol for 2 seconds and then the PARAMETER field will start flashing again (showing the number 14).
7. To leave the set-up mode, place the DIP1 in OFF.

Once the programming phase is correctly accomplished, the LED D15 stops flashing.

If the LED D15 continues flashings with a sequence of 2 flashes the limit switches are not duly set.

Once the limits are set, to tune only one of the two limit positions go to the single parameter 12 or 14 as previously explained.

If the LED D15 shows a sequence of 4 flashes it means that an incorrect encoder direction of rotation has been entered in parameter 11. Change the value of parameter 11 by choosing the opposite direction of rotation according to paragraph 5.2.

Once the value changed, start with the limit switch adjustment procedure once again.

5.4 FINE-TUNING OF ENCODER LIMIT SWITCH

UP LIMIT SWITCH POSITION TUNING

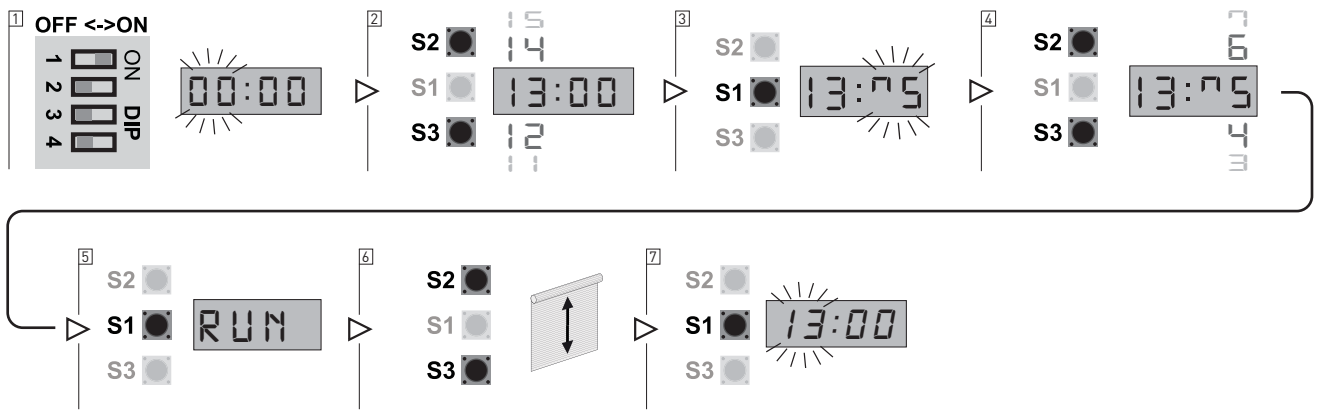

1. Put DIP 1 (S4) in ON position, PARAMETER digits start blinking
2. Select parameter 13 using the buttons OPEN (S2) and CLOSE (S3)
3. Access the field VALUE pressing STOP (S1). In the field VALUE symbol 75 flashes.
4. Using the buttons OPEN (S2) and CLOSE (S3) vary the value:
 - from 4 to 1: progressively decrease the UP position;
 - from 6 to 9: progressively increase the UP position.

The adjustment range is max $\pm 0.8\%$ of the travel of the door.
If the value is not to be changed you can return to the field PARAMETER pressing the STOP button (S1).
5. After modifying the VALUE press the STOP button (S1) to confirm: the display will show RUN.
6. You can test the varied position of the door by moving it through the buttons OPEN (S2) and CLOSE (S3).
7. Press the STOP button (S1) once again to confirm the tuning and return to the PARAMETER field.
8. To leave the set-up mode, place the DIP1 in OFF.

DOWN LIMIT SWITCH POSITION TUNING

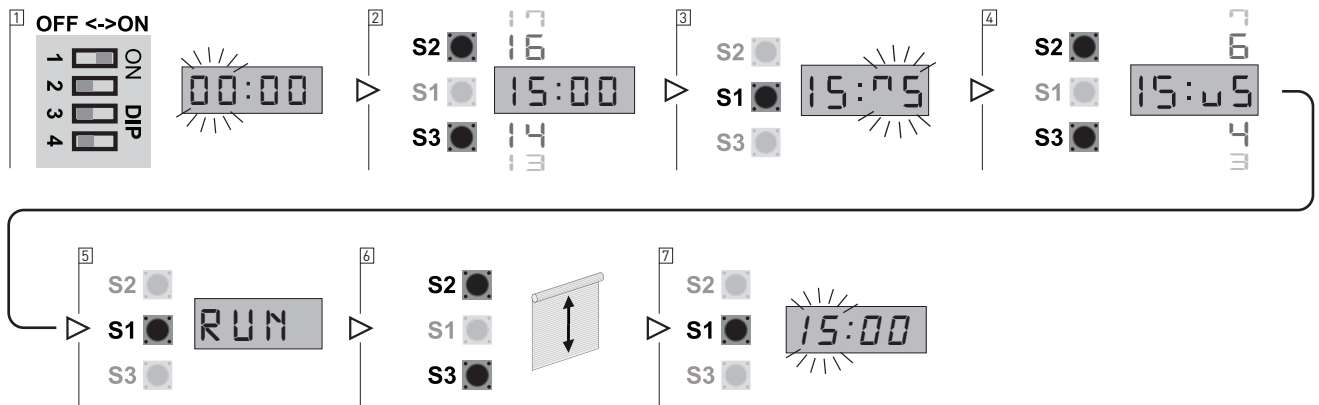

1. Put DIP 1 (S4) in ON position, PARAMETER digits start blinking
2. Select parameter 15 using the buttons OPEN (S2) and CLOSE (S3)
3. Access the field VALUE pressing STOP (S1). In the field VALUE symbol 45 flashes.
4. Using the buttons OPEN (S2) and CLOSE (S3) vary the value:
 - from 4 to 1: progressively decreases the DOWN position;
 - from 6 to 9: progressively increases the DOWN position.

The adjustment range is max $\pm 0.8\%$ of the travel of the door.
If the value is not to be changed you can return to the field PARAMETER pressing the STOP button (S1).
5. After modifying the VALUE press the STOP button (S1) to confirm: the display will show RUN.
6. You can test the varied position of the door by moving it through the buttons OPEN (S2) and CLOSE (S3).
7. Press the STOP button (S1) once again to confirm the tuning and return to the PARAMETER field.
8. To leave the set-up mode, place the DIP1 in OFF.

6. OPERATION WITH MOTOR WITH MECHANICAL LIMIT SWITCHES

6.1 CONNECTING MECHANICAL LIMIT SWITCHES

The wiring is preset for encoder limit switch. To set-up the control unit to mechanical limit switch it's needed to modify the wiring as shown below (fig. 6).

WARNING: connect a control unit pre-set for mechanical limits to a motor with encoder limits, the motor does not perform correctly. In particular, the motor will not find the limit positions and this could put at risk the safety of people and/or things.

The limit switches connector (1) of the multicore cable NRG CAB must be connected to the male connector (2) of the cable the control unit is provided with (Fig. 6a).

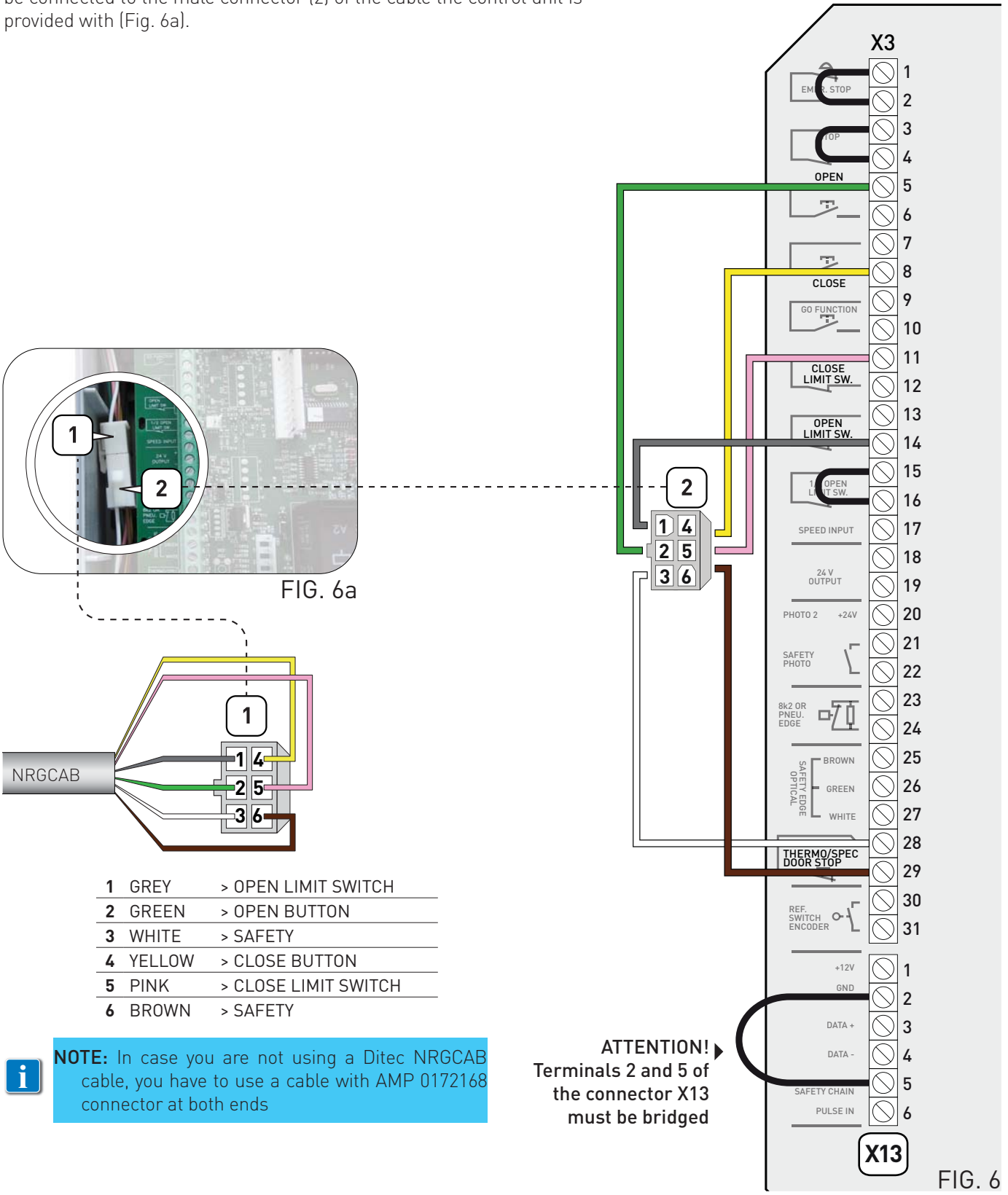





FIG. 6

IP2358EN

6.2 CONFIGURATION FOR MECHANICAL LIMIT SWITCH

1. Check the configuration; the parameter must be set for the use of mechanical limit switches: .
2. Only take care to check the direction of rotation of the motor:
 - by pressing the OPEN button (S2), the door must open;
 - by pressing the CLOSE button (S3), the door must close.Otherwise proceed as described in paragraph 2.2.
3. Check that the motor and the control unit are connected as shown in section 6.1 and that the DIP switch S4 is in OFF.
If correctly installed all LEDs are off and the display will show the symbol  which indicates that the motor is positioned between the two limit switches.
4. Check that:
 - pressing the UP button the motor moves the door upwards (the display shows: );
 - pressing DOWN button the motor moves the door downwards (the display shows: .

UP LIMIT SWITCH ADJUSTMENT

Adjust the UP limit switch cam.

When the UP microswitch is pressed, the display will show the symbol:  and the LED D14 will switch on.

DOWN LIMIT SWITCH ADJUSTMENT

Adjust the DOWN limit switch cam.

When the DOWN microswitch is pressed, the display will show the symbol:  and the LED D12 will switch on.

The door will move between the two positions set by the limit switches cams according to the operation mode shown in parameter 01 (see section 7).



WARNING: the standard mode of the control unit is dead-man (parameter 01). During the mechanical limit switch adjustment use this mode.

Refer to section 7 for the other modes of operation.

7. OPERATION MODE

The control unit is pre-set in dead-man control mode (PARAMETER 01, VALUE 01).

 Hold-to-run OPEN
Hold-to-run CLOSE (Put a bridge in X3 between terminal 23-24 when there is no safety device)

 Impulsive OPEN
Hold-to-run CLOSE (Put a bridge in X3 between terminal 23-24 when there is no safety device)

 Impulsive OPEN; Impulsive CLOSE. **REQUIRED WITH RADIO MODULE NRGZENX1 - OPTIONAL**

 Not in use

It is possible, however, to define different working modes by modifying the value of PARAMETER 01:



WARNING: it is highly recommended to activate the impulsive mode only after having completed the set-up and adjustments of the control unit. In particular, during the mechanical limit switches adjustment select always the dead-man operation mode.

During the encoder limit switches set-up the control unit will only allow the dead-man working mode.

8. WORKING TIME SET-UP

PARAMETER 51 defines the working time of the door.

WARNING! The default parameter is the **51:02** that is to say a working time of 40 seconds.

To turn off or modify the working time, follow this procedure:

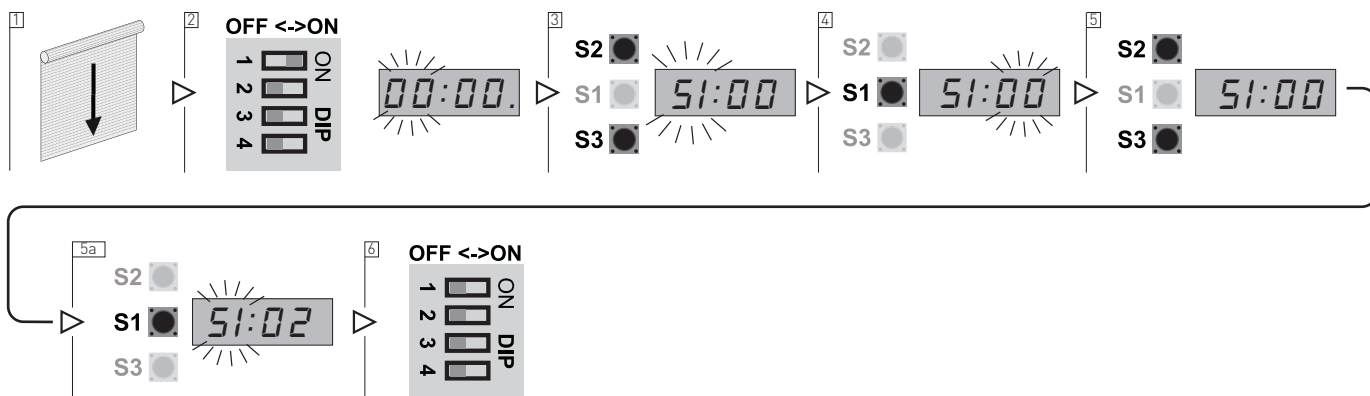

1. Close the door and stop at the DOWN limit position.
2. Put DIP 1 (S4) in ON position, PARAMETER digits start blinking
3. Using the buttons OPEN (S2) and CLOSE (S3) select the parameter 51
4. Access the field VALUE pressing STOP (S1)
5. Using the buttons OPEN (S2) and CLOSE (S3) vary the value:
 - **VALUE 00**: Function inactive.
 - **VALUE 01**: Working time 20 seconds.
 - **VALUE 02**: Working time 40 seconds (default).
 - **VALUE 03**: Activate the self learning function to determine the working time.

CAUTION: In order to use this function the limit switches must be already adjusted.

- **VALUE 04**: Working time 60 seconds
- 5a. Select the value **00 / 01 / 02 / 04** > press STOP (S1) to confirm
 - 6a. Place the DIP1 again in OFF to be out of the set-up mode.

By selecting a working time, the control unit verify if the door moving time exceeds the predetermined value: if this happens the door will stop and the display will shows the error code E:03.

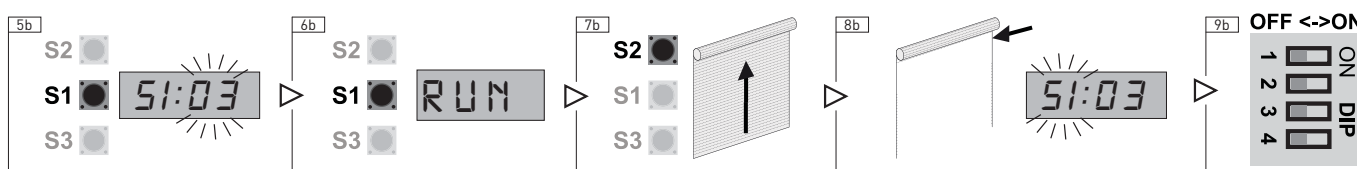

- 5b. Select value 03
- 6b. Press STOP (S1) to confirm. The control unit, showing **RUN** is ready to move the door
- 7b. Using the OPEN button (S2) move the door from the closed position to the open position without interruptions.
- 8b. Once the UP limit switch is reached, the door stops, RUN stops flashing and the display will automatically return to field PARAMETER.
- 9b. To leave the set-up mode, place the DIP1 in OFF.

9. AUTOMATIC CLOSING

Parameter 32 allows the selection of the door automatic closing after a selectable period of time.

IMPORTANT: parameter 32 is visible and accessible only if parameter 01 has been set in impulsive mode **01:03**. It will be activated only if on parameter 31 is selected at least one photocell (par. 13.1)

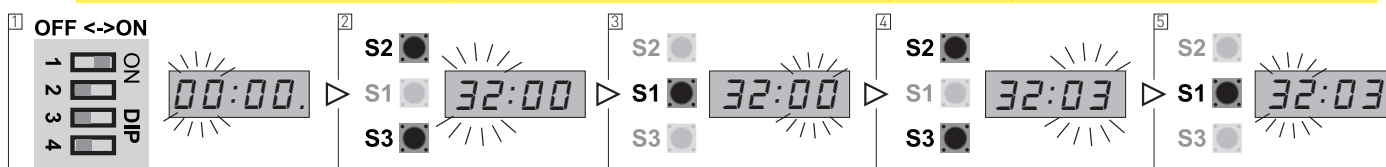

1. Put DIP 1 (S4) in ON position, PARAMETER digits start blinking
2. Using the buttons OPEN (S2) and CLOSE (S3) select the parameter 32

3. Access the field VALUE pressing STOP (S1)
4. Using the buttons OPEN (S2) and CLOSE (S3) vary the value
 - The value 00 in the field VALUE inhibits the automatic closing;
 - A value greater than 0, from 1 to 99, indicates the number of seconds to wait before the activation of the automatic closing:



NOTE: From 0 to 99 the change is made every second by using the buttons OPEN and CLOSE.
Over 99 the change is made every 10 seconds and the value will flash quickly: for example, the VALUE 18 corresponds to 180 seconds, the value 19 to 190 seconds ...
If you keep the OPEN button pressed you will get a fast increase of the value.

5. Press STOP (S1) to confirm.
6. To leave the set-up mode, place the DIP1 in OFF.

10. "CAR WASH" FUNCTION

Count down of auto closing time starts, only if photo has been activated more than "photo active time". Door shall be complete closed before start of a new cycle.



ATTENTION: parameter 33 is selectable only if in the parameter 31 is selected at least one photocell.

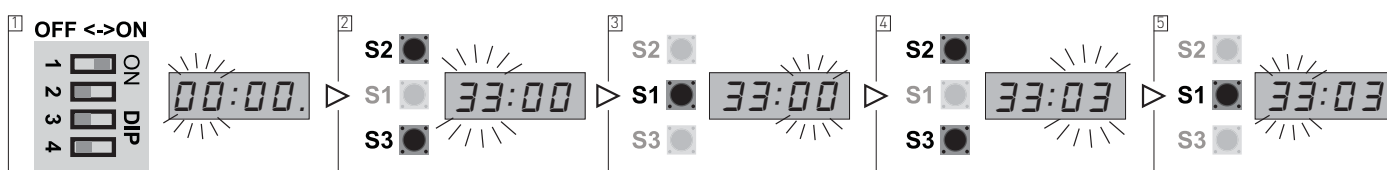

1. Close the door and stop at the DOWN limit position.
2. Put DIP 1 (S4) in ON position, PARAMETER digits start blinking
3. Using the buttons OPEN (S2) and CLOSE (S3) select the PARAMETER 51
4. Access the field VALUE pressing STOP (S1)
5. Using the buttons OPEN (S2) and CLOSE (S3) vary the value:
 - **>00** Photo active time in 0,1 sec. Units (e. g. 15 = 1,5 sec.) - (Adjustable 1 – 30 units – 0,1 sec. to 3,0 sec.)
6. Press STOP (S1) to confirm.
7. To leave the set-up mode, place the DIP1 in OFF.

11. TEMPORARY DISABLING OF AUTOMATIC CLOSING

The function stops the automatic closing if activated.

The countdown on the display shows the value of the pre-set waiting time. To activate the temporary lock, with the door in its UP limit position, hold the STOP button or the emergency stop button for more than 5 seconds.

To restore the automatic closing press CLOSE button or the closing on "GO Function".



ATTENTION! Parameter 36 is visible and selectable only if the automatic closing has been selected in parameter 32.

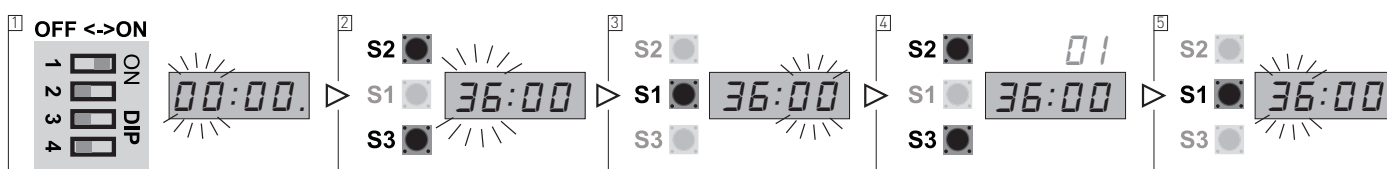

To enable the temporary disabling of automatic closing:

1. Put DIP 1 (S4) in ON position, PARAMETER digits start blinking
2. Using the buttons OPEN (S2) and CLOSE (S3) select the parameter 36
3. Access the field VALUE pressing STOP (S1)
4. Using the buttons OPEN (S2) and CLOSE (S3) vary the value:
 - **VALUE 00:** function OFF;
 - **VALUE 01:** function ON.
5. Press STOP (S1) to confirm.
6. To leave the set-up mode, place the DIP1 in OFF.

12. PARTIAL OPENING WITH ENCODER LIMIT SWITCHES

With encoder limit switches type, the partial opening can occur through the use of a selector or of an additional button.

To use this feature, the parameter 16 must be configured with a value >01.

If you are using a selector, this one must be connected to terminals 15 and 16 of X3.

If you open the contact of the selector, the use of the partial opening is inhibited.

If you close the contact of the selector, pressing the UP button, the door stops at the partial opening.

The partial opening can be adjusted by setting the PARAMETER 16 at values from 02 to 07 with a progressive change of the partial opening from 50% to 75% of the travel.

1. Put DIP 1 (S4) in ON position, PARAMETER digits start blinking

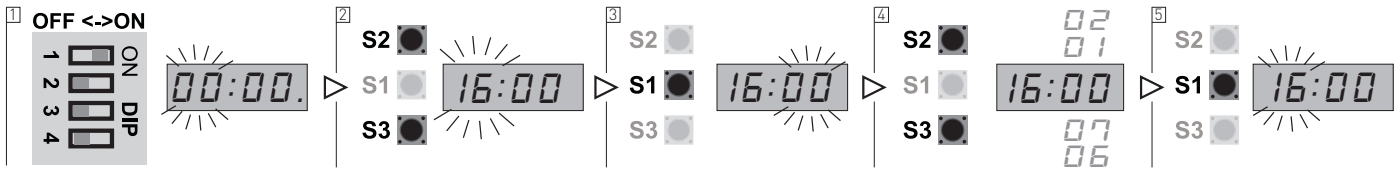

2. Using the buttons OPEN (S2) and CLOSE (S3) select the parameter 16

3. Access the field VALUE pressing STOP (S1)

4. Using the buttons OPEN (S2) and CLOSE (S3) vary the value:

- **VALUE 02:** Partial opening at 50% of the travel
- **VALUE 03:** Partial opening at 55% of the travel
- **VALUE 04:** Partial opening at 60% of the travel
- **VALUE 05:** Partial opening at 65% of the travel
- **VALUE 06:** Partial opening at 70% of the travel
- **VALUE 07:** Partial opening at 75% of the travel

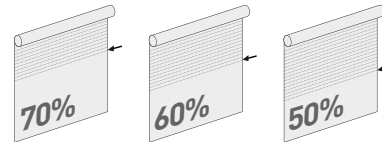

5. Press STOP (S1) to confirm

If you are using an additional button, this one must be connected to terminals 15 and 16 of X3.

In this case the UP button allows the opening of the door up to the UP limit position.

While, to move the door to the partial opening you have to press the additional button.

The partial opening can be determined by setting the PARAMETER 16 with values from 08 to 13 with a progressive change of the partial opening from 50% to 75% of the travel:

- **VALUE 08:** Partial opening at 50% of the travel
- **VALUE 09:** Partial opening at 55% of the travel
- **VALUE 10:** Partial opening at 60% of the travel
- **VALUE 11:** Partial opening at 65% of the travel
- **VALUE 12:** Partial opening at 70% of the travel
- **VALUE 13:** Partial opening at 75% of the travel

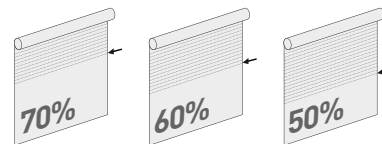

12.1 AUTOMATIC CLOSING FROM PARTIAL OPENING

You can set the automatic closing even from the partial opening setting the PARAMETER 17.

1. Activate the automatic closing function (chapter 9).

2. Set the PARAMETER 17:

- **VALUE 00:** Automatic closing (from partial opening) OFF.
- **VALUE 01:** Automatic closing (from partial opening) ON.

13. SAFETY DEVICES

13.1 PHOTOCELLS

i NOTE: Refer to the photocells instructions for the DC supply.

- A 24V DC supply for the photocells is available:
- Terminal 18 of X3 (or terminal 4 of X12) for the positive.
 - Terminal 19 of X3 (or terminal 2 of X12) for the mass.

! ATTENTION! Both the transmitter and the receiver of the photocells must be connected to the same terminals.

! WARNING: connect the photocells out contacts between 18 and 22 terminal of the X3 clamp or between 1 and 3 terminal of the X12 clamp, otherwise the photocells test cycle will fails showing on the display the error code **E:05** and preventing the control unit working.
In case of an incorrect connection, restore the correct connections and press stop to start a new test cycle.

Through parameter 31 you can conform the control unit to the type of connection that you are going to select, in order to activate the corresponding test functions.

This test allows the control unit to constantly check of short circuits or malfunctions that could compromise the safety of the device. The test thus allows to ensure the safety even in case of single failure as required by the standards EN13241-1 and EN-12453.

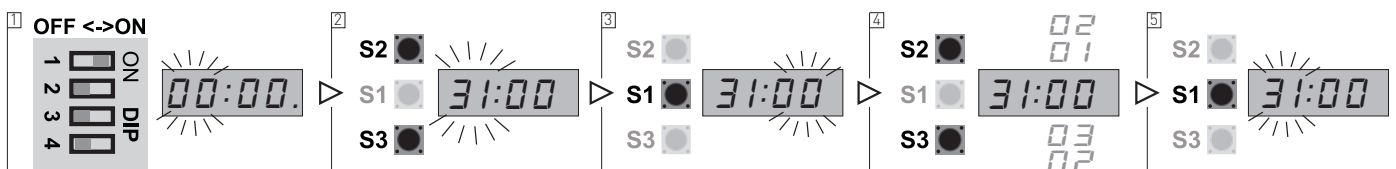

- Put DIP 1 (S4) in ON position, PARAMETER digits start blinking
- Using the buttons OPEN (S2) and CLOSE (S3) select the parameter 31
- Access the field VALUE pressing STOP (S1)
- Using the buttons OPEN (S2) and CLOSE (S3) vary the value:
 - **VALUE 00:** No photocells connected
 - **VALUE 01:** Connection PHOTO 1 on X12
 - **VALUE 02:** Connection PHOTO 2 on X3
 - **VALUE 03:** Connection PHOTO 1 and 2
- Press STOP (S1) to confirm.
- To leave the set-up mode, place the DIP1 in OFF.

PHOTOCELLS FUNCTION DESCRIPTION

In case something interposes between the transmitter and the receiver, this one activates a sequence of commands depending on the door status when it was interrupted:

STATUS OF THE DOOR	CONTROL UNIT FEEDBACK
The door is stopped	The display shows the symbol F-1: 2
	Closing is prevented
	Opening allowed to the UP limit position
The door is opening	The display shows the symbol F-1: 2
	Opening continues until the UP limit position is reached
	Closing is prevented
The door is closing	The display shows the symbol F-1: 2
	In case of impulsive operation mode: it reverses the direction to the complete opening
	In the case of dead-man operation mode: it stops and reverses upwards

13.2 SAFETY EDGE

Safety edge connection: in case of resistive safety edges 8.2KΩ (type SOFA and SOFB) or pneumatic safety edges, connect the wires to the terminals 23 and 24 of X3.

In case of optoelectronic safety edge, connect the wires to the terminals 25, 26 and 27 of X3 (respecting the color order).

WARNING: if you choose the optical safety edge (VALUE 03) the terminals 23 and 24 DO NOT have to be connected by a jumper.

WARNING: if you DO NOT want to use a safety edge, select the VALUE 01 and connect the terminals 23 and 24 with a jumper. The terminals 25, 26 and 27 of X3 must not be connected.

WARNING: the safety edge must be connected before the selection of PARAMETER 21, but do not activated them. If this happens, the control unit shows an error signal on the display the code

The same happens if you choose a parameter that does not match with the connected terminals.

Through PARAMETER 21 you can select the type of safety edge.

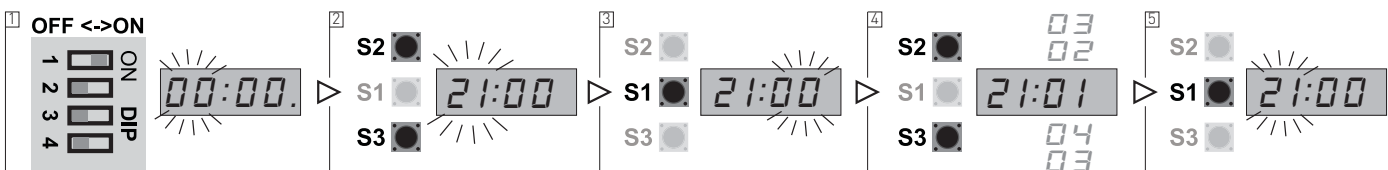

1. Put DIP 1 (S4) in ON position, PARAMETER digits start blinking
2. Using the buttons OPEN (S2) and CLOSE (S3) select the parameter 21
3. Access the field VALUE pressing STOP (S1)
4. Using the buttons OPEN (S2) and CLOSE (S3) vary the value
 - **VALUE 01:** PNE / DW pneumatic.
 - **VALUE 02:** Safety edge with resistive contact 8.2KΩ.
 - **VALUE 03:** Optoelectronic edge.
 - **VALUE 04:** Special LP / DW pneumatic.
5. Press STOP (S1) to confirm.
6. To leave the set-up mode, place the DIP1 in OFF.

SAFETY EDGE FUNCTION DESCRIPTION

In case the safety edge is activated the control unit makes a sequence of commands depending on the door status at the time of activation:

STATUS OF THE DOOR	CONTROL UNIT FEEDBACK
The door is stopped	The display shows the symbol
	Closing is prevented
	Opening allowed to the UP limit position
The door is opening	The display shows the symbol
	Opening continues until the UP limit position is reached
	Closing is prevented
The door is closing	The display shows the symbol
	In case of impulsive operation mode: it reverses the direction to the complete opening
	In the case of dead-man operation mode: it stops and reverses upwards

13.3 SECONDARY MOVABLE SAFETY EDGE

Connection of the secondary movable safety edge: in case of 8.2KΩ resistive or pneumatic movable safety edge (SOFA and SOFB series), connect the conductors of the safety edge to the terminals 3 and 4 of connector X20.



ATTENTION: the movable safety edge must be connected before selecting PARAMETER 23, but it must not be activated. If this happens, the station sends back an error signal by showing the **Err** code on the display.

The same thing happens if you choose a parameter that does not correspond to the connected terminals.

It is possible to determine the type of secondary movable safety edge used on the door through PARAMETER 23.

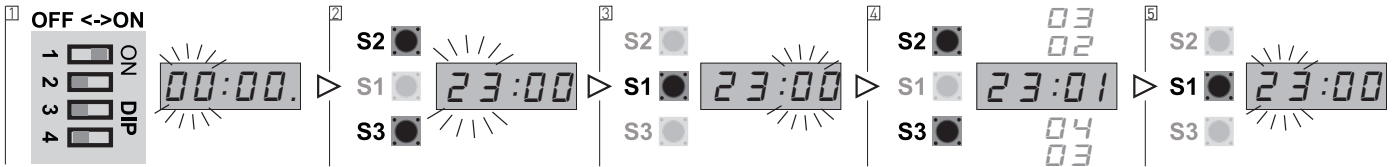

1. Put DIP 1 (S4) in ON position, PARAMETER digits start blinking.
2. Using the buttons OPEN (S2) and CLOSE (S3) select the parameter 23.
3. Access the field VALUE pressing STOP (S1).
4. Select the preferred value by pressing buttons S2 and S3:
 - **VALUE 00:** no secondary movable safety edge connected.
 - **VALUE 01:** the secondary movable safety edge works in parallel to the primary */**.
 - **VALUE 02:** the secondary movable safety edge stops the door while it is opening*.
 - **VALUE 03:** the secondary movable safety edge stops the door while it is closing by inverting the direction*.
5. Press STOP (S1) to confirm.
6. To leave the set-up mode, place the DIP1 in OFF.

NOTES

* The secondary movable safety edge must be PNE/air or 8.2KΩ type. Anyway, it has to be of the same type of the primary movable safety edge. **If parameter 88:03 (electromechanical lock) is set, it will not be possible to connect a secondary movable safety edge.**

** For the anti-shears function, please connect a photocell instead of a movable safety edge.

13.4 AUX RELÈ MANGEMENT (max 230Vac/5A)

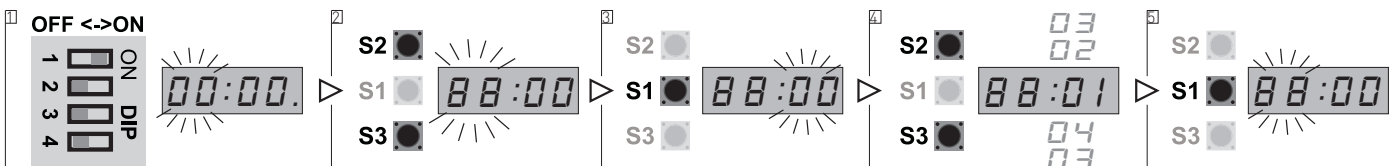

Through PARAMETER 88 it is possible to determine the behavior of relé K3.

1. Put DIP 1 (S4) in ON position, PARAMETER digits start blinking
2. Using the buttons OPEN (S2) and CLOSE (S3) select the parameter 88
3. Access the field VALUE pressing STOP (S1)
4. Select the preferred value by pressing buttons S2 and S3:
 - **VALUE 00:** active relé while the door is moving
 - **VALUE 01:** active relé while the door is in the DOWN limit switch position
 - **VALUE 02:** active relé while the door is in the UP limit switch position
 - **VALUE 03:** the relé is used for the electromechanical lock: it activates for one second during the opening and ONLY if the door is closed
5. Press STOP (S1) to confirm
6. To leave the set-up mode, place the DIP1 in OFF

14. PARAMETER LIST

i NOTE: **bold** values and underlined text correspond to the factory settings.

! ATTENTION: set the limit switches (par. 5 or par. 6) before to adjust any parameter.

01 > OPERATION MODE pag. 17

- 01:01** Hold-to-run OPEN - Hold-to-run CLOSE
- 01:02** Impulse OPEN - Hold-to-run CLOSE
- 01:03** Impulse OPEN - Impulse CLOSE
- 01:04** Not in use

02 > REACTION – FAILURE ON PHOTOCCELL OR SAFETY EDGE LIST

- 02:00** Hold to run operation not possible when failure on photo or safety edge list
- 02:01** Hold to run possible when failure on photo or safety edge list

11 > SELECTION OF LIMITS pag. 13

- 11:00** Mechanical limits
- 11:05** Encoder - standard installation
- 11:06** Encoder - not standard installation

12 > TUNING OF ELECTRONIC LIMIT OPEN pag. 14

See instructions (pg. 13)

13 > FINE TUNING OF ELECTRONIC LIMIT OPEN pag. 15

See instructions (pg. 14)

14 > TUNING OF ELECTRONIC LIMIT CLOSE pag. 14

See instructions (pg. 14)

15 > FINE TUNING OF ELECTRONIC LIMIT CLOSE pag. 15

See instructions (pg. 15)

16 > PARTIAL OPENING pag. 20

- 16:00** No active
- 16:01** Partial opening active. Position controlled by mechanical micro switch
- 16:02** Partial opening active. Electronic limit on 50 % open position
- 16:03** Partial opening active. Electronic limit on 55 % open position
- 16:04** Partial opening active. Electronic limit on 60 % open position
- 16:05** Partial opening active. Electronic limit on 65 % open position
- 16:06** Partial opening active. Electronic limit on 70 % open position
- 16:07** Partial opening active. Electronic limit on 75 % open position
- 16:08** Partial opening active. Electronic limit on 50 % open position
- 16:09** Partial opening active. Electronic limit on 55 % open position
- 16:10** Partial opening active. Electronic limit on 60 % open position
- 16:11** Partial opening active. Electronic limit on 65 % open position
- 16:12** Partial opening active. Electronic limit on 70 % open position
- 16:13** Partial opening active. Electronic limit on 75 % open position

17 > AUTO CLOSE FROM ½ OPEN

- 17:00** No active
- 17:01** Active

21 > SAFETY EDGE SELECTION pag. 22

- 21:01** PNE / DW air switch
- 21:02** 8.2KΩ electrical (SOFA and SOFB series)
- 21:03** Optical
- 21:04** Special LP DW air switch

! ATTENTION: if it is **NOT** use a safety edge, see instruction paragraph 12.2 .

22 > AFTER RUN

- 21:00** No after run
- >00** After run active – after run time 0.01 – 0.50 sec.

23 > EXTRA SAFETY EDGE

pag. 22

- 23:00** No extra safety edge list
- 23:01** Extra safety edge list works parallel with primary safety edge list
- 23:02** Extra safety list stops door in opening direction
- 23:03** Extra safety list stops door and reverse a little in opening direction

29 > DISENGAGEMENT

Function that allows the disengagement on stop during losing.

- 29:00** No wire tighten function
- 29:01** Wire tighten 5mS
- 29:02** Wire tighten 10mS
- 29:03** Wire tighten 20mS
- 29:04** Wire tighten 30mS

31 > PHOTOCELLS SETTINGS

pag. 21

- 31:00** No Photo safety connected
- 31:01** Photo 1 connected
- 31:02** Photo 2 connected
- 31:03** Photo 1 and 2 connected

32 > AUTO CLOSE SELECT

pag. 18

- 32:00** No auto closing
- >00** Seconds 1 – 990 (after 99 the changing will be in x10 of seconds and the value is flashing quickly)

33 > CAR WASH FUNCTION

pag. 19

- 33:00** No car wash function
- >00** Photocell active time in 0,1 sec. Units (e. g. 15 = 1,5sec.) - (Adjustable 1 – 30 units – 0,1 sec. to 3,0sec.)

34 > "FORCED" CLOSING

Configurable only when "car wash" is active.

- 34:00** No forced closing
- 34:01** Forced closing after 2min (even though photocell has not been activated)
- 34:02** Forced closing after 5min (even though photocell has not been activated)
- 34:03** Forced closing after 10min (even though photocell has not been activated)
- 34:04** Forced closing after 20min (even though photocell has not been activated)

35 > OPTIONAL RADIO MODULE NRGZENX1 - "GO FUNCTION"

pag. 28

- 35:00** Normal go function (Closing is only possible from open limit)
- 35:01** Special go function (stop command possible in opening direction)
- 35:02** Go function with open function only
- 35:03** Operation's logic step-by-step

36 > TEMPORARY DISABLING OF AUTOMATIC CLOSING

pag. 19

- 36:00** Function OFF
- 36:01** Function ON

41 > FORCE CONTROL SETTINGS

- 41:00** Default value. Not to be modified

51 > RUN TIME CONTROL

- 51:00** No run time control
- 51:01** Run time 20 sec
- 51:02** Run time 40 sec
- 51:03** Automatic learning
- 51:04** Run time 60 sec

52 > REVERSE TIME OF SAFETY EDGE

Reverse time of safety edge in 1/100 seconds. 0.00 – 0.99 sec. **(default 0,004 sec.)**

53 > REVERSE TIME OF PHOTOCCELL

Reverse time of Photo in 1/100 seconds. 0.05 – 0.99 sec. **(default 0,30 sec.)**

58 > SERVICE COUNTER SETUP

- 58:00** No Service countdown
- 58:01** 15 open cycles before service (for test only)
- 58:02** 5000 open cycles before service
- 58:03** 10000 open cycles before service
- 58:04** 20000 open cycles before service

59 > SERVICE COUNT ALERT

- 59:00** Display shows E:04
- 59:01** Switch to hold-to-run control and display shows E:04

81 > DELAY TIME INDICATION OF MISSING ENCODER POSITION

- 81:00** 1 second
- 81:01** 2 second
- 81:02** 4 second
- 81:03** 4 second with automatic reset

84 > SPECIAL OPEN FUNCTION

- 84:00** Normal open function
- 84:01** Special open function (Open signal with high priority. The door will always open on a continuously open signal, even after a stop command)

88 > OPTION RELAY (K3)

- 88:00** Relay active when door is running
- 88:01** Relay active when the door is closed
- 88:02** Relay active when the door is open
- 88:03** Relay used for electric lock

15. FLASHING LIGHT CONNECTION (230Vac with self-flashing) / COURTESY LIGHT

15.1 FLASHING LIGHT

The flashing light will be active during the movement of the door. Set PARAMETER 88= 00.

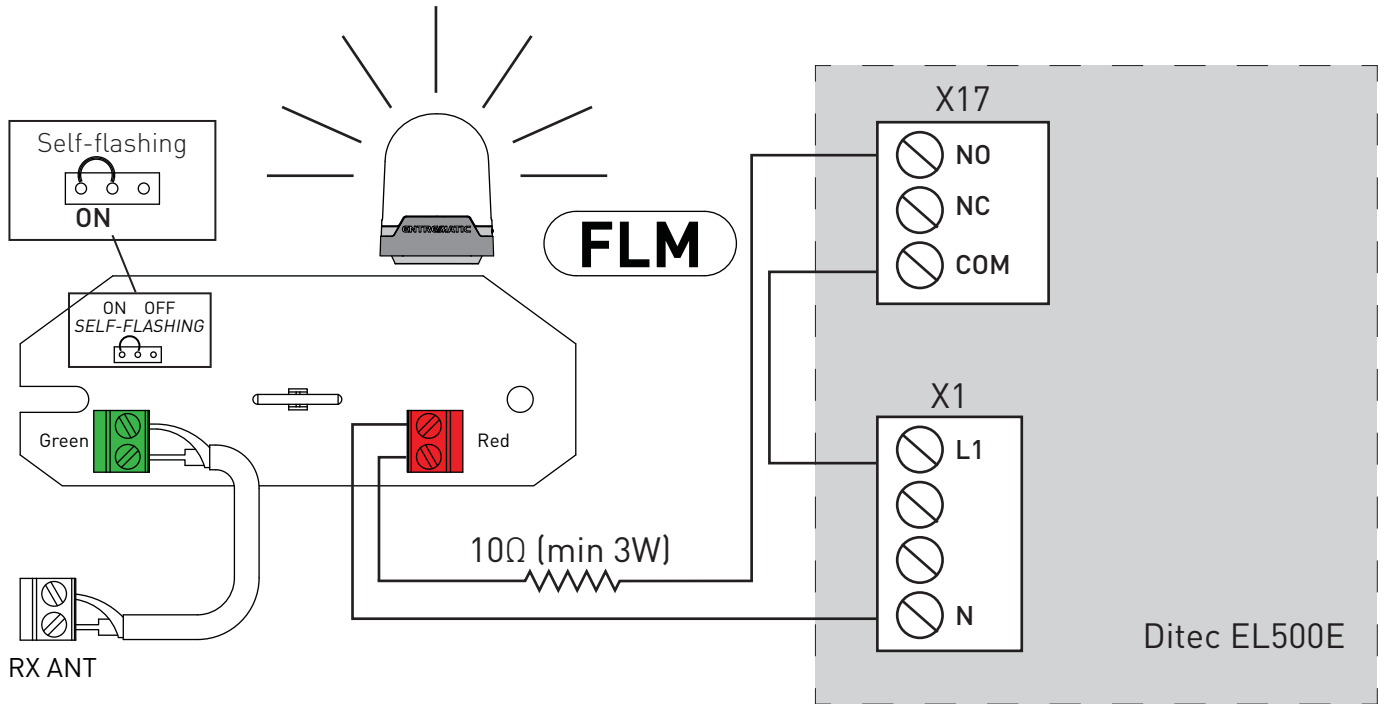

WARNING: connect in series a wire-wound resistor (10Ω, min 3W)

15.2 COURTESY LIGHT

The flashing light works as courtesy light. Set PARAMETER 88= 00.

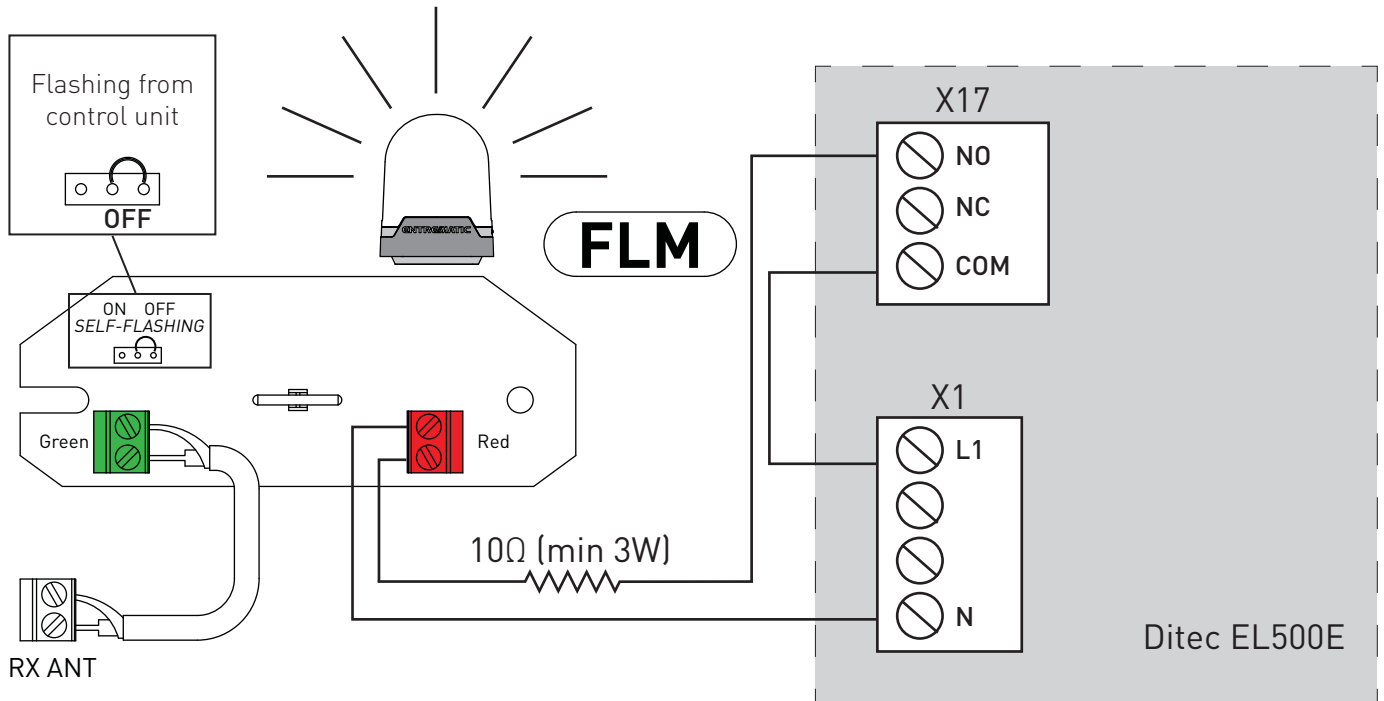

WARNING: connect in series a wire-wound resistor (10Ω, min 3W)

15.3 ADDITIONAL RADIO RECEIVER MODULE NRGZENX1 (OPTIONAL)

The control unit can be radio operated thanks to the ZEN transmitter. The BIXMR2 storage module of the radio receiver can contain up to 200 transmitters. The ZEN transmitter must be matched to the NRGZENX1 radio receiver already connected to slot X7 (see page 6).

Please look at the instructions attached to the NRGZENX1 radio receiver in order to connect it to the control unit and to match it to the transmitter.



NOTE: Set working mode:

01:03 Impulsive OPEN; Impulsive CLOSE.

Once the NRGZENX1 radio receiver is inserted, you can set up its operation mode through PARAMETER 35 (parameter 35 is visible ONLY if the photocell is active through parameter 31):

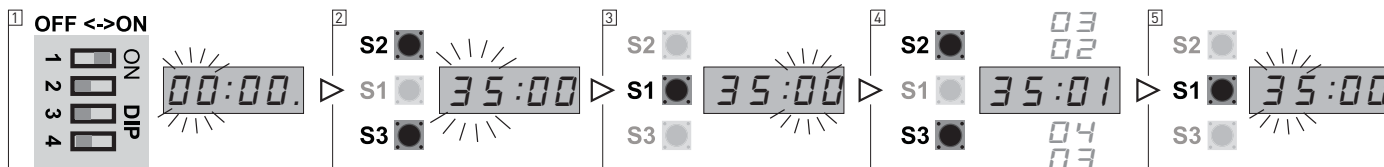

1. Put DIP 1 (S4) in ON position, PARAMETER digits start blinking
2. Using the buttons OPEN (S2) and CLOSE (S3) select the parameter 35
3. Access the field VALUE pressing STOP (S1)
4. Select the preferred value by pressing buttons S2 and S3:

- **VALUE 00. MODE OF OPERATION "CONDOMINIUM"**

The signal of the transmitter always commands the opening, except when the door is already completely opened. In this case it commands the closure.

- **VALUE 01. MODE OF OPERATION "CONDOMINIUM" + STOP**

The signal stops the movement of the door ONLY while opening.

- **VALUE 02. MODE OF OPERATION "ONLY OPENING"**

The signal of the transmitter **ONLY** activates the opening of the door. If the door is closing, the signal changes the movement till the UP limit switch position has been reached.

- **VALUE 03. MODE OF OPERATION "STEP-BY-STEP"**

Every time the signal of the transmitter is activated, it accomplishes the following commands: OPEN > STOP > CLOSE > STOP sequentially.

NOTE: if the AUTOMATIC CLOSURE has been programmed, during the pause the signal of the transmitter will extend the pause by resetting the timer of the automatic closure.

5. Press STOP (S1) to confirm.
6. To leave the set-up mode, place the DIP1 in OFF.















15.4 "GO FUNCTION"

On input 9-10 of X3 terminal is available the function "GO FUNCTION" that defines the pulse mode of operation. In case the Ditec radio receiver NRGZENX1 is not used, it is possible to cable third party receivers and to define the mode of operation.

The way of functioning for "GO FUNCTION" is selectable on parameter 35 following the procedure above (paragraph 15.3).

16 SIGNAL VISUALIZED ON THE DISPLAY

The display will in run mode show status of limits, some inputs or error codes if they occurs. When power up the software version is showed shortly.

DISPLAY	DESCRIPTION
	<ul style="list-style-type: none"> Nothing active. (4 chairs symbol) Door is stopped between limits and no errors are found.
	Open limit active (S2)
	Close limit active
	Partial opening
	Active stop
	OPEN push-button active (S2)
	CLOSE push-button active (S3)
	GO function active (NOTE: that the door only can be closed by GO function, when photocell is installed)
	Photocell 1 active Photocell 2 is external photocells mounted in the screw terminals X12.
	Photocell 2 active Photocell 2 is external photocells mounted in the screw terminals X3.
	Safety Edge active
	Safety list not mounted correct / wrong selection in parameter 21
	Door running up
	Door running down

17. TROUBLESHOOTING

D10 - STOP active
 (X3:1-2, X3:3-4, X3:28-29, X13:2-5, X2:4-5)
 LED is also active in fail mode. Observe display and
 D15 ERROR LED

D13 - Open Limit

D16 - Close Limit

D15 - Error diode - it shows the error code

D12 - Close Limit active

D14 - Open Limit active

D28 - Power ON to Open contactor

D29 - Power ON to Close contactor

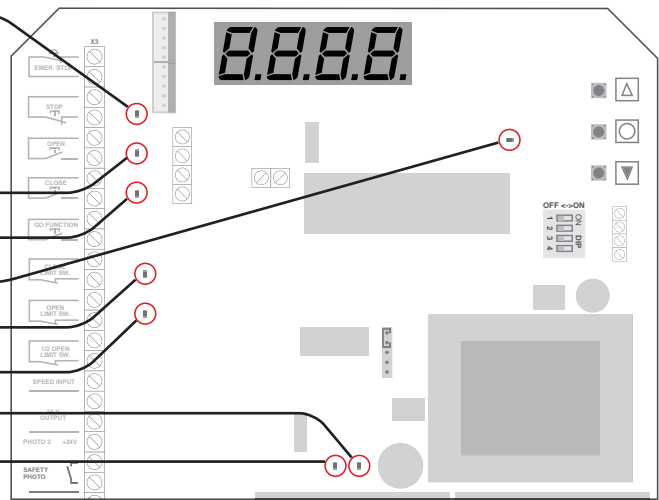













17.1 ERROR CODES - D15 ERROR LED



(used when electronic limits is selected)

Flashes on error LED D15	Error explanation	Solving error
1	No answer from encoder (No 24Vdc control voltage)	Check connections Check the 24VDC voltage in terminal 18-19 of X3
2	Limits not learned	Learn limits
3	Motor running unintended	Service needed. Fatal error. Move the door manual to middle position without power. Change from normal mode to programming mode on DIP switch no.1. This will clear the SER error. If the door is running again in 1 sec. without command when power is on then the PCB is defect.
4	Calculation error	Check that parameter 11 value is correct selected. (Left/right turning select). Possible user error – both limits are the same. Encoder error.
5	Not in use	
6	Not in use	
7	Encoder: position out of learned range.	Re-learn limits
	Encoder – wrong selection of left/right turning	Check that parameter 11 value is correct selected. (Left/right turning select) or re-learn limits
8	Encoder – Failure operating voltage	Check connection and supply voltage. Change encoder
9	EEPROM failure on IC4 by power up	Re-learn limits and make a new power-up. (In that order!) Or Make a factory resetting and a new power-up. (In that order!)

17.2 DISPLAY ERROR CODE

DISPLAY	DESCRIPTION
	Error code. Door is running without command Service needed. Fatal error. Move the door manual to middle position without power. Change from normal mode to programming mode on DIP switch no. 1. This will clear the SER error. If the door is running again in 1 sec. without command when power is on then the PCB is defect.
	Error code. Edge monitoring Error code Monitoring failure of safety edge if this function is activated. Check or adjust safety edge list.
	Error code. Run time Error code. Door is stopped on run time control.
	Error code. Service Service counter decremented to 0 Reset for new countdown
	Error code. Photocell Failure in photocell circuit. (Test cycle after last stop failed, Press STOP to start new test)
	Error code. Safety Edge Failure in edge circuit. (Test cycle after last stop failed, Press STOP to start new test)
	Error code. no change of encoder position, when running. Door started, but the position is not changing. Door is stopped after delay time and E:09 failure is shown about 1 sec. Possible errors: The door is blocked, disengaged, cable connection error or the encoder magnet is not fixed on the shaft. Reset of E09: both limits shall be founded again by hold-to-run steps. (If it is not possible to find both limits, the limits must be relearned) If necessary, adjust in parameter 81 (delay time) Parameter 81:03 = autoreset
	Error code. EEPROM Fail Possible error: Limits has been changed, after the force control has been learned. Reset of E20: Try deactivating force control in parameter 41 (41:00) and after this make a new power-up.
	Error code. EEPROM Fail EEPROM failure of power-up. Try factory clear or change processor (paragraph 4.3).
	Error on 24V and/or 12V voltage circuit 24/12V is shorted or overloaded.
and	
	
or	
	

All rights related to this material are the exclusive property of Entrematic Group AB. Although the contents of this publication have been compiled with the greatest possible care, Entrematic Group AB cannot accept liability for any damage that might arise from errors or omissions in this publication. We reserve the right to make modifications without prior notice. No part of this publication may be copied, scanned, adapted or modified without prior permission in writing from Entrematic Group AB.

 The crossed-out wheeled bin symbol indicates that the product should be disposed of separately from household waste. The product should be handed in for recycling in accordance with local environmental regulations for  waste disposal. By separating a marked item from household waste, you will help reduce the volume of waste sent to incinerators or landfill and minimize any potential negative impact on human health and the environment.



Entrematic Group AB
Lodjursgatan 10
SE-261 44, Landskrona
Sweden
www.entrematic.com